



LUG EVERYTHING,
treat yourself!

Safety, efficiency and performance



SERVICE LIFT

EL-403

Commercial/Institutional

The Élévabec service lift is designed to ease the handling of small objects from one floor to the other as well as to improve users' safety. While taking little space, this little service-lift will allow saving time and money as well as being the essential device ensuring ease and safety.

ADVANTAGES:

- Fits in small space
- Safe
- Moves smoothly
- Noiseless mechanism
- Easy to use
- Needs little care

**Specially designed for use in facilities such as:
childcare centre, convent, office building, laboratory, manor and restaurant.**

info@elevabec.com | www.elevabec.com | 1 800 311-9977 | 450 773-9977

6555 Choquette Avenue, Saint-Hyacinthe (Québec) J2S 8L2

This device is in accordance with the CAN/CSA-B44 standard. It can be installed in any public, residential or commercial facility. Québec product.

RBQ : 8277-1106-03

SERVICE LIFT

EL-403



The EL-403 service lift is an efficient and easy to use handling device. It is ideal for handling dishes or trays, boxes, parcels for the office or storage room or any other move of small items. Designed according to current standards and highly save, this little service-lift meets the requirements in institutional and commercial buildings...

Why not at home?

MAIN SPECIFICATIONS

Applicable norms	CSA-B44, section 7
Course / Trajectory	Maximum 30 feet **Calculated from the lower floor to the top floor**
Capacity / Rated load	200 lb (118 kg) 595 lb (270 kg)

CABIN

Cabin structure	Stainless steel 304 #4 or food grade
Cabin dimensions	30" X 30" (762 mm X 762 mm) 24" X 24" (610 mm X 610 mm) 20" X 20" (508 mm X 508 mm)
Cabin height	36" (914 mm)
Interior finish	Stainless steel 304 #4 or food grade
In-cabin lighting	Energy efficient light (optional) Heating light (optional)
In-cabin options	Removable full or perforated shelves Removable tray shelf



Swing landing door

Sliding landing door

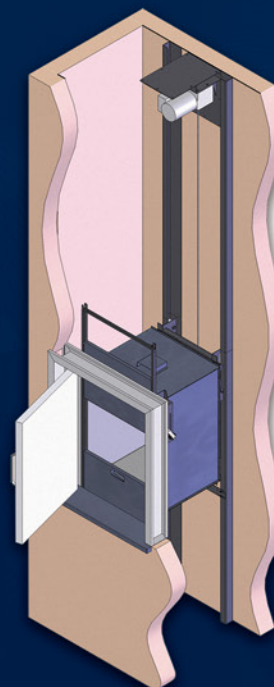

CONFIGURATIONS:

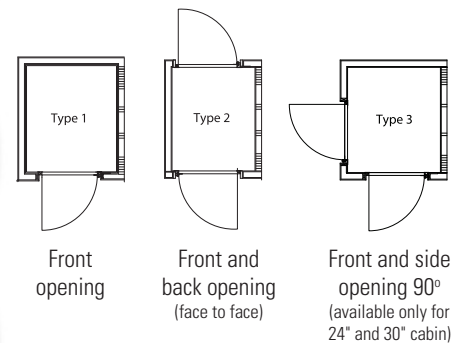

SERVICE LIFT

EL-403



CONTROL BUTTONS

Control panel, push buttons and indicators

LANDING CALL PANELS

Direct acting call/send buttons (momentary pressure)

Engraved lamicoid

Recessed call plate in the landing door frame

Optional:

- Engraved stainless steel call plate
- Independent call plate (on wall)
- Key selector "on/off"

Indicators:

- Sound alarm for at floor cabin arrival
- Tell-tale light on top of landing door:
 - Open door
 - Cabin at landing

DOORS

Landing and cabin doors

LANDING DOORS AND CABIN DOORS

- Swing type (available finishes: primer or stainless steel)

Landing doors height: 38¼" (972 mm)

Landing doors, possible widths: 38¼" (972 mm) / 30" (762 mm) / 24" (610 mm) / 20" (508 mm)

- Tailored guillotine type sliding landing doors, (stainless steel) (Option)
- Fireproof steel 90 minutes ULC

Cabin doors

CABIN DOORS

Stainless steel synchronized double guillotine

TECHNICAL SPECIFICATIONS

DRIVE MECHANISM

Movement speed

DRIVE MECHANISM

Approximative movement speed:

30"/minute (0.15 meter/second)

50"/minute (0.25 meter/second)

SECURITY

Parachutes

Security breaks: Type A

Landing lock

Electromechanics GAL type N

Security device on the doors avoiding the movement of the service-lift if a door is not properly closed. The landing door remains locked if the device is in operation or the cabin is not on the floor.

See the service-lift EL-403 technical sheet for more information.